

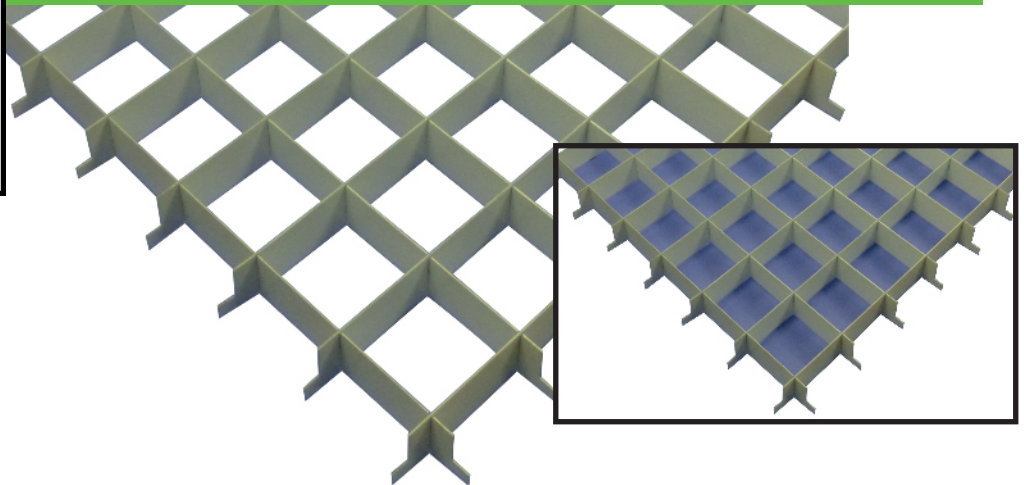

**SLP** (UK) LIMITED  
LIGHTING & CEILING COMPONENTS

# Mono-Cell



Monocell is a square cell ceiling louvre made from flat pre-coated aluminium blades pressed together to form a lightweight open cell ceiling panel. It is designed for use with a standard (24mm) table modular exposed lay-in (butt cut or joggled) ceiling grid system. The panels are simply laid into the 'T' grid system to provide a quality, yet economical open cell ceiling installation that provides masking of the void and easy access to services. Panels can be installed either tegular or flush fit by turning the panel 180° into the grid.

The conventional modular nature of panels and cells allows easy integration of services and lighting. With an open area in excess of 95%, is ideal for installation below sprinkler systems.

Standard Profile Height:	30 mm
Standard Cell Size:	50 x 50 & 75 x 75
Standard Colour:	White
Standard Panel Size:	600 x 600 mm
Standard edge profile:	Tegular / Flush

**Other variations on panel sizes or special colours are available to special order. All dimensions shown are in millimetres and nominal.**

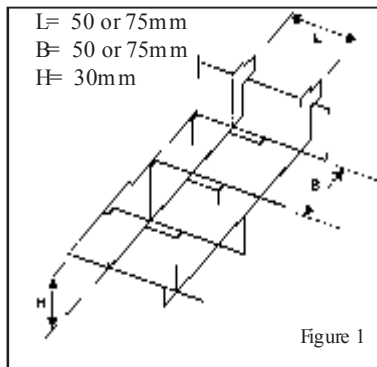

#### Description

**Monocell** open cell ceiling panels are specifically designed to fit modular 600 x 600mm and 1200 x 600mm standard 24mm table exposed grid suspended ceiling systems. Panels are lightweight yet strong with flush or tegular mounting options (figure 2).

#### Recommended Applications

**Monocell** fits most proprietary standard 24mm table exposed grid systems with a 600 x 600mm and 1200 x 600mm module size. They are ideal for use in Superstores, Hypermarkets, Retail Stores and Showrooms. They provide a functional, low cost open cell ceiling to obscure services in the void and a ceiling with a large open area. This allows sprinkler systems above to function without hindrance. **Monocell** is ideal for areas requiring a high degree of ventilation.

#### Composition and Colour

**Monocell** louvres are made from lightweight pre-painted aluminium flat blades. The side edges of each louvre blade are rebated to provide two mounting options, either flush or tegular (figure 2).

#### Appearance

The standard finish for a Monocell Louvre is pre-painted White Gloss. Other finishes and colours are available to special order.

#### Shape, Weight & Dimensions

The standard sizes of Monocell Louvres measure 600 x 600mm and 1200 x 600mm nominally and are available in cell sizes of 50 x 50mm, 75 x 75mm. Other panel and cell sizes are available on receipt of a special order. Depth is 30mm. Please refer to our sales office for weights, open area and visual cut off angles (figure 1).

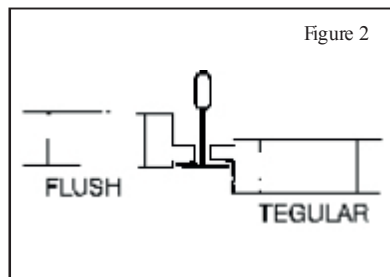

Open Cell Ceiling